

Tip #1

Seven Simple Steps to Frame and Raised Panel Construction

The procedure outlined here covers construction techniques for making straight-edged stiles and rails from 3/4" thick lumber, using only the table saw.

The creation of stiles and rails with decorative edges requires the use of special shaper cutters, such as [Shopsmith's Complete Cabinet Set](#) - or router bits, such as [Shopsmith's Reversible Stile & Rail Bit](#).

IMPORTANT NOTE: Since upper saw guards cannot be used when making these cuts, push sticks, featherboards and proper safety devices should be used at all times to help avoid injury when making the cuts shown in this procedure.

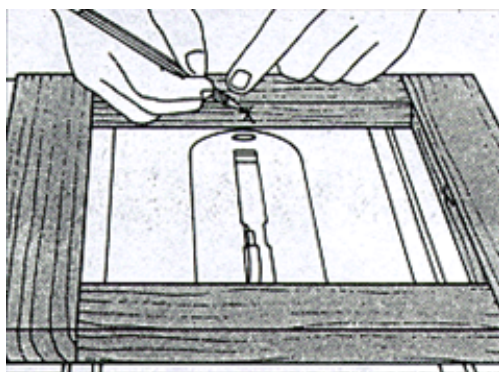

STEP 1: Cut your door stiles (vertical boards) & rails (horizontal boards) to fit your cabinet door opening. Rail lengths should equal the width of the door opening minus twice the width of one stile plus 1" (twice the 1/2" depth of the groove you'll cut in the rails). Mark the inside face of each stile and rail to avoid confusion when cutting the grooves.

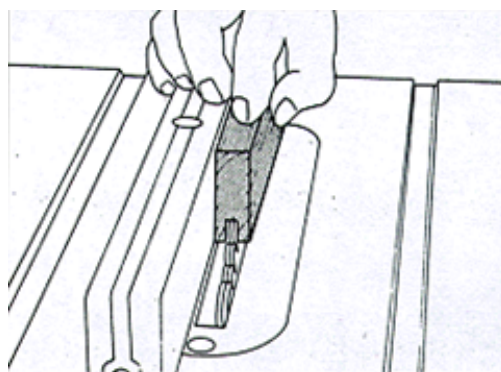

STEP 2: Set up your [Dado Blade Set](#) to cut the grooves on the insides of your stiles and rails. Since we're cutting a 1/4" wide groove, use only the two outer blades of your Dado Blade Set. Center the blades in the standard Table Saw Insert, being sure both sides of the insert support the stock during the cut. Set your Rip Fence 1/4" from the right side of your Dado Blades with the blade tips 1/2" above the surface of your worktable

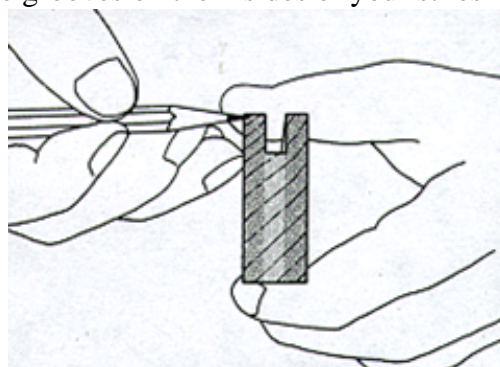

(to make a 1/2" deep cut). Be certain your blade is set to make your cut in the exact center of the stile/rail edge. Make a test cut on a piece of scrap to verify this.

STEP 3: The joinery for your frame members is created by removing the face stock on both ends of your rails, leaving a tongue of exactly the thickness (or width) of the groove you cut on the insides of your stiles and rails in step 2 above (1/4" in our example).

STEP 4: Re-adjust your Dado Blade's depth-of-cut to 1/4" and use your Miter Gauge to form a 1/2" long by 1/4" thick tenon on each end of your two rails. (Blade height setting formula: Subtract the thickness of your tenon from the thickness of your stock and divide by two).

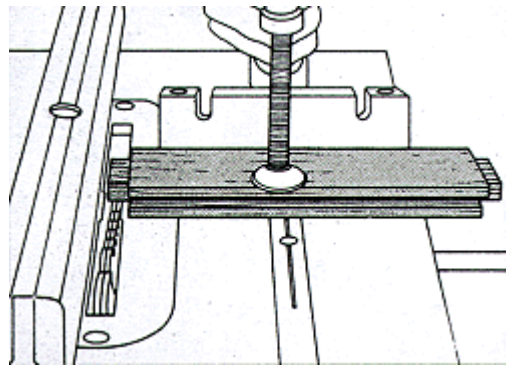

STEP 5: Make a special panel-raising fixture such as one of the two shown here. Click on each picture to see larger view.

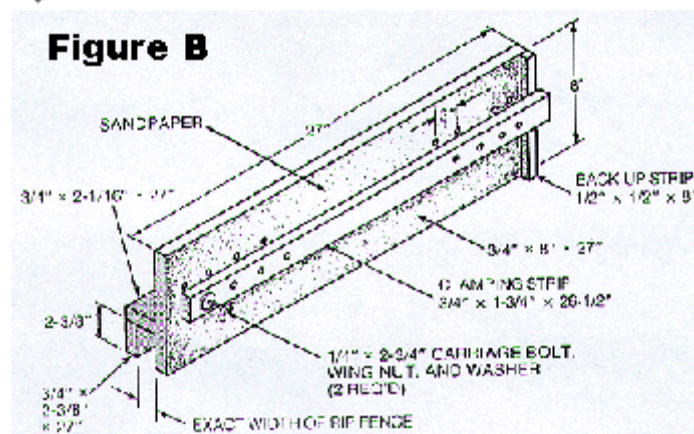
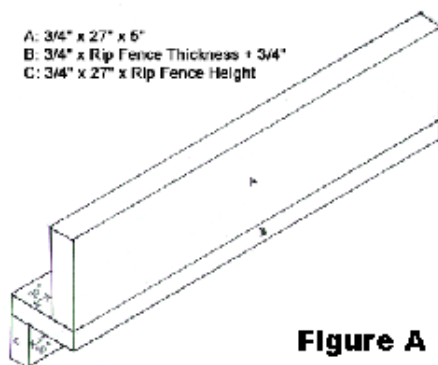

STEP 6: Set your worktable tilt angle at 15-degrees. If you're using the simplified panel raising jig ("A"), as shown here, adjust the distance between where your blade protrudes through the table surface and the edge of your rip fence to be 3/16". This way, the edge of your raised panel will be 1/16" thinner than the groove you cut in your stiles and rails to accept the panel. If you're using the more elaborate panel-raising jig ("B"), adjust the distance between where your blade protrudes through the table surface and the edge of your panel-raising jig to be 3/16". Set your saw blade's depth-of-cut so the inside edge of your blade penetrates the stock fully at the 15-degree angle. Clamp a test piece of stock firmly into your jig and make a test cut to verify all settings. Once you're satisfied that all settings have been properly made, make your cuts around all four edges of your panel. Hand sand or scrape to smooth your cuts.

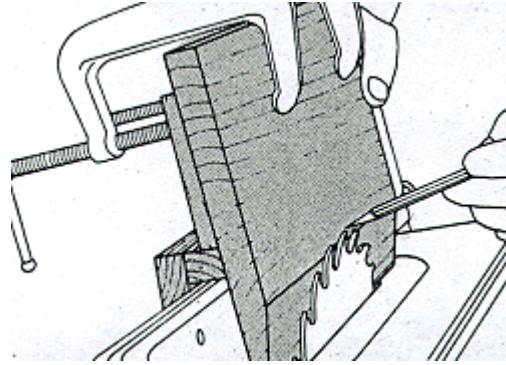

STEP 7: Apply a finish to your panel before placing it into your frame. Glue and clamp the door frame stiles and rails together, leaving the panel un-glued to allow room for it to expand and contract with changes in the weather and environment. Figure 1/4" of clearance per foot of panel width for expansion.

